

SPECIFICATIONS

TW022WA05 22 mm textile tweeter, low resonance, 4 ohm

TW022WA05 is a tweeter designed for applications requiring the highest level of performance and most extended and linear high frequency response.

Innovation

Tweeters used to feature a separate rear chamber in order to obtain low resonance frequency. Not any longer. By designing the internal parts to accommodate new larger internal volumes, the TW022WA05 offers an unusually low resonance frequency.

The design with 22 mm voice coil and wide surround caters for both applications that would normally require traditional ¾" tweeters and those, where 1" tweeters would usually be used.

FEATURES

- 22 mm design for optimal compromise between on- and off-axis frequency response, resonance frequency, and power handling
- Internal volumes for low resonance frequency and distortion
- Precision-coated textile diaphragm for improved consistency and high-frequency extension
- Optimized dome shape for ultra high frequency cutoff
- Vented voice coil former for reduced distortion and compression
- Copper-clad aluminium voice coil wire offering lower moving mass for improved efficiency and transient response
- Build-in cavities under dome/edge to equalize pressure for lower distortion and lower resonance frequency
- Flexible lead wires for higher power handling and larger excursion
- Gold plated terminals to prevent oxidation and ensure long-term reliable connection
- Delivered with EVA gasket attached for hassle-free mounting and secure cabinet sealing



PRELIMINARY NOMINAL SPECIFICATIONS

Notes	Parameter	Value	Unit
	Nominal size	22	[mm]
	Nominal impedance	4	[ohm]
	Recommended frequency range	2 - 25	[kHz]
1, 5	Sensitivity, 2.83V/1m (average SPL in range 2.5 - 20 kHz)	91.5	[dB]
2	Power handling, short term, IEC 268-5, no additional filtering		[W]
2	Power handling, long term, IEC 268-5, no additional filtering		[W]
2	Power handling, continuous, IEC 268-5, no additional filtering		[W]
	Effective radiating area, S _d	6.6	[cm ²]
3, 5	Resonance frequency (free air, no baffle), F _s	775	[Hz]
	Moving mass, incl. air (free air, no baffle), M _{ms}	0.21	[g]
3	Force factor, BxI		[N/A]
3, 5	Suspension compliance, C _{ms}		[mm/N]
3, 5	Equivalent air volume, V _{as}		[lit.]
3, 5	Mechanical resistance, R _{ms}		[Ns/m]
3, 5	Mechanical Q, Q _{ms}		[-]
3, 5	Electrical Q, Q _{es}		[-]
3, 5	Total Q, Q _{ts}		[-]
4	Voice coil resistance, R _{DC}	3.7	[ohm]
6	Voice coil inductance, L _e (measured at 10 kHz)		[μH]
	Voice coil inside diameter	22	[mm]
	Voice coil winding height	1.6	[mm]
	Air gap height	2.5	[mm]
	Magnet weight		[g]
	Total unit net weight excl. packaging		[kg]
3, 6	K _{rm}		[mohm]
3, 6	E _{rm}		[-]
3, 6	K _{xm}		[mH]
3, 6	E _{xm}		[-]

Note 1 Measured in infinite baffle.

Note 2 Tested in free air (no cabinet).

Note 3 Measured using a semi-constant current source, nominal level 2 mA.

Note 4 Measured at 20 deg. C

Note 5 Measured at 25 deg. C

Note 6 It is generally a rough simplification to assume that loudspeaker transducer voice coils exhibit the characteristics of an inductor. Instead it is a far more accurate approach to use the more advanced model often referred to as the "Wright empirical model", also used in LEAP-4 as the TSL model (www.linearx.com), involving parameters K_{rm}, E_{rm}, K_{xm}, and E_{xm}. This more accurate transducer model is described in a technical paper [here at our web site](#).

SPECIFICATIONS

TW022WA05 22 mm textile tweeter, low resonance, 4 ohm

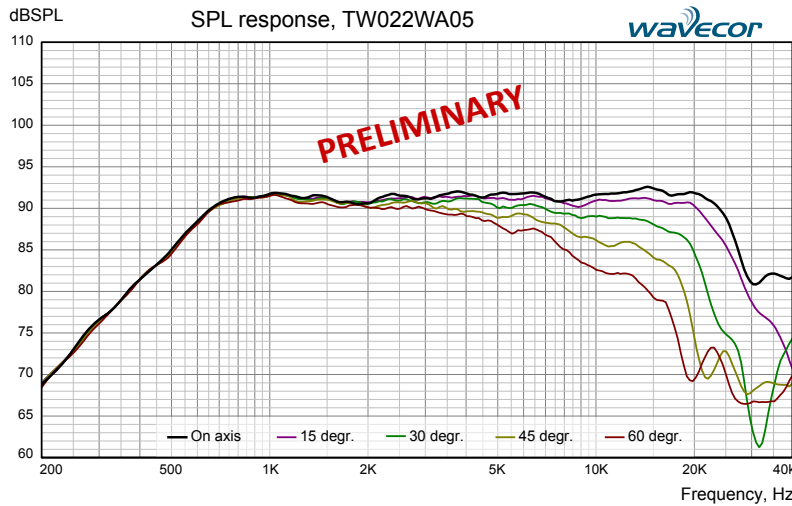

OUTLINE DRAWING (nominal dimensions, mm)

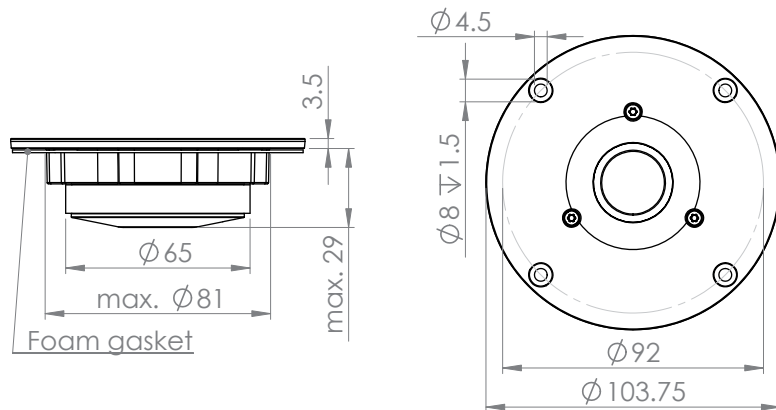

CONNECTIONS (nominal dimensions, mm)

Terminal plating: Gold
 Thickness, both terminals: 0.5 mm

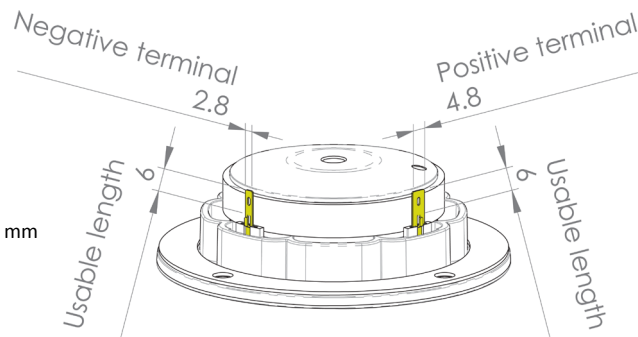

PACKAGING AND ORDERING INFORMATION

Part no. TW022WA05-01	Packaged individually (one piece per box)
Part no. TW022WA05-02	Bulk packaging

Latest update: September 15, 2011